

Virtual test bench as a complement to study thermal area: application in vapor compression systems

Banco de pruebas virtual como complemento para el estudio del área térmica: aplicación en sistemas de compresión de vapor

Juan Manuel Belman-Flores^{1*}, Juan Manuel Barroso-Maldonado¹, Santos Mendez-Díaz² and Simón Martínez-Martínez²

¹Departamento de Ingeniería Mecánica, División de Ingenierías, Universidad de Guanajuato. Campus Irapuato-Salamanca. Comunidad de Palo Blanco. C. P. 36885. Salamanca, México.

²Facultad de Ingeniería Mecánica y Eléctrica, Universidad Autónoma de Nuevo León. Av. Pedro de Alba s/n, Ciudad Universitaria. C. P. 66451. San Nicolás de los Garza, México.

ARTICLE INFO

Received December 15, 2014

Accepted July 6, 2015

KEYWORDS

Education, simulator, refrigeration, engineering students, learning

Educación, simulador, refrigeración, estudiantes de ingeniería, aprendizaje

ABSTRACT: This paper describes an educational simulator developed in the software Engineering Equation Solver to simulate the behavior of a vapor compression system. The application is focused on educational purposes, specifically for handling skills in refrigeration facilities by students in engineering careers. Using this simulator, the students are able to analyze easily the influence of the measured parameters (such as the compressor rotation speed, volumetric flow rates and temperature of the secondary fluids) on the energy performance of the facility and its components. The virtual test bench consists of a primary screen showing a general scheme of the vapor compression facility with input and output parameters. From this primary screen, the performance of the main components can be analyzed. Finally, this virtual test bench was tested by engineering students, concluding that the simulator is an interesting tool as improvement and support for learning in different subjects.

RESUMEN: Este artículo describe un simulador educativo desarrollado en el software *Engineering Equation Solver* para representar el comportamiento de un sistema de compresión de vapor. La aplicación está enfocada con propósitos educativos, particularmente para que estudiantes de ingeniería adquieran habilidades en el manejo de instalaciones de refrigeración. Mediante el uso de este simulador, los estudiantes tendrán la capacidad de analizar fácilmente la influencia que tienen parámetros medidos experimentalmente (como la velocidad de rotación del compresor, el flujo volumétrico y la temperatura de fluidos secundarios) sobre la eficiencia energética del sistema y sus componentes principales. El banco virtual consta de una pantalla principal que muestra un esquema general del sistema de compresión de vapor con parámetros de entrada y de salida. Desde la pantalla principal, el desempeño de los componentes principales puede ser analizado. Finalmente, este banco de pruebas virtual ha sido probado por estudiantes de ingeniería, concluyendo que el simulador es una herramienta de apoyo que permite mejorar el aprendizaje de las diferentes áreas del conocimiento.

1. Nomenclature

A surface (m²)
 C volumetric flow rate (m³ s⁻¹)
 SS static superheating degree (K)

\dot{m} mass flow rate (kg s⁻¹)
 p pressure (MPa)
 Pot_{comp} power consumption (kW)
 \dot{Q} thermal power (kW)
 rp compression ratio

* Corresponding author: Juan Manuel Belman Flores
 e-mail: jfbelman@ugto.mx
 ISSN 0120-6230
 e-ISSN 2422-2844

Greek letters

| | |
|---------------|----------------------------------|
| ϵ | heat exchanger efficiency |
| η_v | compressor volumetric efficiency |
| η_{comb} | compressor combined efficiency |

Subscripts

| | |
|------|------------------------------|
| amb | ambient |
| cond | condensation, condenser |
| drc | desuperheating |
| evap | evaporation, evaporator |
| in | inlet |
| rec | superheating |
| ref | refrigerant |
| out | outlet |
| sc | secondary fluid (condenser) |
| se | secondary fluid (evaporator) |
| sub | subcooling |

2. Introduction

Higher education institutions adapt their programs as scientific and technological advances emerge, providing students with the necessary tools for a relevant learning. Furthermore, within the engineering teaching process, scientific thinking and engineering skills should be noted by using information and communication technologies, which leads to an increased motivation and efficiency in problem solving [1].

The educators in the engineering field have invented several new and innovative ways of teaching subjects. In this context, the engineering programs look for the use of different tools as software and virtual labs for teaching in different areas [2, 3]. Acquiring the ability to work with computer programs that enrich learning is part of the formation of any engineering student. In relation to the courses offered in the thermal engineering area, there is a need to reinforce the knowledge acquired in the classroom at a laboratory level. In various subjects, experimental benches are necessary for the completion of practices that complement the theoretical part. However, certain disadvantages sometimes occur when there is a limited access to such facilities. For instance, there are many very specific practices, which are analyzed for given operating conditions; in other situations, we are working with large

groups of students due to the availability of the facility, and in many cases, the time of completion of the practice is too long. Thus, a virtual test bench represents an opportunity as a complementary tool in learning for engineering students. On the other hand, these simulators and virtual labs can be used as tools to help students to understand the performance of the whole simulated system of each separate component and the relations among them.

In different areas of thermal engineering, it is possible to find educational simulators; such is the case of Dsym, a simulator developed in Pascal and Delphi environment [4] by incorporating fundamental equations, mass and energy balances, and equilibrium equations. The authors encourage students to learn in a simple and iterative way by a thermodynamic simulation of distillation towers. An alternative for the analysis and optimization of hydraulic and thermal models is the use of an Excel spreadsheet application implemented for conducting thermal power cycles, evaluation and the search for optimal designs of hydraulic network systems [5]. Another example is the software developed in Visual Basic EasyCFD used as a tool for educational purposes in the simulation of dynamics fluid and energy transfer [6]. The software CyclePad [7] is used to analyze and design thermodynamic cycles such as power plants, engines, refrigeration and heat pumps. Students using the software as an indication can find all the information about components and equipment, which can be coupled to construct thermodynamic cycles and its analysis by assigning input parameters. Educational software for teaching and learning about the dynamics and control of shell and tube heat exchangers allows students to change operation and design conditions such as temperature, number and length of tubes, diameter of tubes, etc. [8]. In a similar way, educational software for the design of heat exchanger networks is presented [9], the program is able to assist students through all the main steps of the design, including the energy and cost targeting, design, the heat exchanger network, and the optimization analysis. The use of the program improves the efficiency of the course since it lets students practice the concepts on the pinch method while relieving them of tedious and repetitive calculations.

Thus, the simulations are recognized as an efficient and effective method in teaching and learning in the field of engineering. The researchers and students using these tools should be fully aware of the physical principles underlying the thermal energy systems under consideration. In the thermal area, the theoretical basis acquired by the students in the classroom is very important and, the software using can simulate operating conditions, to improve the knowledge and understanding, all of this without leaving apart the experimental part.

Then, using a computational tool in thermal engineering area is essential, to education, scientific research and industrial applications. The practical experience is essential for good control and improvements in engineering education as well as to achieve a balance between theory and practice, and to encourage active science [10].

3. Refrigeration teaching

Nowadays, the field of vapor compression refrigeration system is the most prevalent type worldwide in domestic refrigeration, commercial and industrial refrigeration and air conditioning. These systems represent considerable energy consumption [11]. For instance, vapor compression chillers in office buildings consume about 50% of the total energy for air conditioning systems, and due to the demand on thermal comfort in buildings, HVAC systems consume about 50% energy [12]. Thus, it is very important that in a mechanical engineering degree program, any student understands the energy and environmental behavior and management of such system. These systems also have a negative impact on the environment due to the use of refrigerants with a high value of global warming [13]. Therefore, [14] developed a thermodynamic compression system to predict the performance of a vapor compression system using alternative refrigerants.

In the literature, some works are focused on education programs for vapor compression systems. Some of them characterize the behavior of individual components; others focus on the overall behavior of the installation by predicting its performance. For instance, [15] through physical basic fundamentals and simple considerations, generated a tutorial for a refrigeration cycle with the goal of reinforcing theoretical concepts to students of Applied Thermodynamics, which allows them to understand the effects in the global operation of the system. A software called SYSREF developed in Visual Basic language for simulation of different cycles of a vapor compression system, primarily focused on the teaching of this technology [16]. This software has several features among the most important are: libraries for components and refrigerants, user-friendly interface and an option for the construction of different refrigeration cycles. The SYSREF software analyzes the influence of input parameters on the performance of components and the global system. CoolPack [17] is a free software developed for simulation, design, sizing and analysis of a vapor compression refrigeration cycle, using it, input parameters are fixed and a number of predefined arrangement cycles can be solved. Regarding commercial software, it is worth mentioning the ART [Advanced Refrigeration Technologies] [18]. This represents a wide software for analysis and optimization of refrigeration and air conditioning based on vapor compression. Cycle_D is another software that allows simulating the performance of refrigeration cycles, whether they are subcritical or transcritical, in which is possible to include modifications to the cycle like employing an intermediate exchanger [19]. Another educational simulator is presented [20], in this study a refrigeration cycle simulator is used. The simulator is prepared in such a way that the interrelation between each component, the system and the surroundings can be analyzed by the students. The simulator is also found to be a crossroads for several subjects, giving an integral picture of the thermal-fluid courses. Another paper describes and evaluates the validation of a novel software package, which simulates the transient and steady-state operation of whole refrigeration systems [21]. This

software allows practitioners to study the implications of the design choices in terms of energy usage and carbon generation in the storage and processing of foodstuff by refrigeration. A spreadsheet application for data filtering and energy analysis, which has applications in research and experimental evaluation of the energy performance of alternative refrigerants, is presented in [22]. The resulting application is user friendly (for engineering students, researchers, etc.), even without VBA programming and interaction of dynamic libraries of REFPROP knowledge by the user.

In this paper, a friendly virtual test bench developed in EES (Engineering Equation Solver) software for educational purposes is presented. The graphic simulation is the application of a physical model of an experimental vapor compression system previously developed and validated. The main contributions of this paper into this field are:

- The virtual bench is robust enough, which demonstrates a suitable approximation to the actual energy performance of the experimental installation, in which the development has been based.
- The simulator uses easy access input data in this type of installations, which only allows the user to manipulate real operational conditions.
- The simulator includes the incorporation of alternative refrigerants such R1234yf substitute ideal of R134a, also of refrigerant R407C.
- The use of this simulator allows students to perform analysis and synthesis of the fundamentals of subjects as: refrigeration and air conditioning, thermodynamics and heat transfer; all of this improves their training and preparation for using this type of refrigeration system.

4. Description of the experimental test bench

The refrigeration test facility (based on vapor compression technology) that was used for developing the education simulator is shown in Figure 1.

The experimental facility consists of a vapor compression circuit and two secondary fluids circuits. The vapor compression circuit is a single-stage vapor compression system using R134a, R407C and R1234yf as working fluids, with an open type variable speed compressor, a shell-and-tube evaporator in which the refrigerant flows inside the tubes and a brine water-propylene glycol (65/35% by volume) is used as secondary fluid. A shell-and-tube condenser with refrigerant flowing along the shell is used and the water inside the tubes as secondary fluid. Finally, the installation has a set of expansion valves.

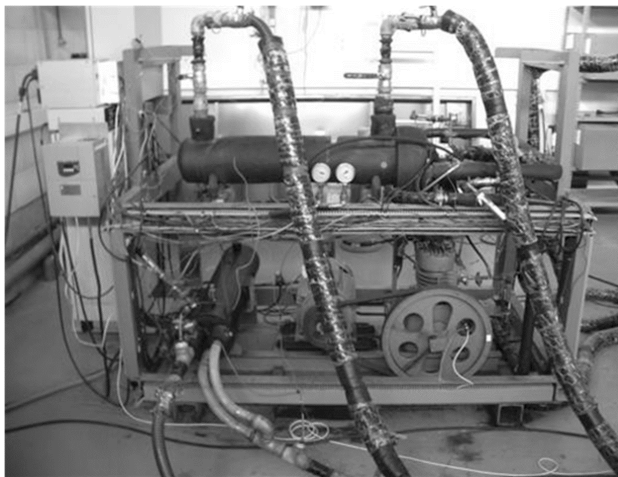

(a)

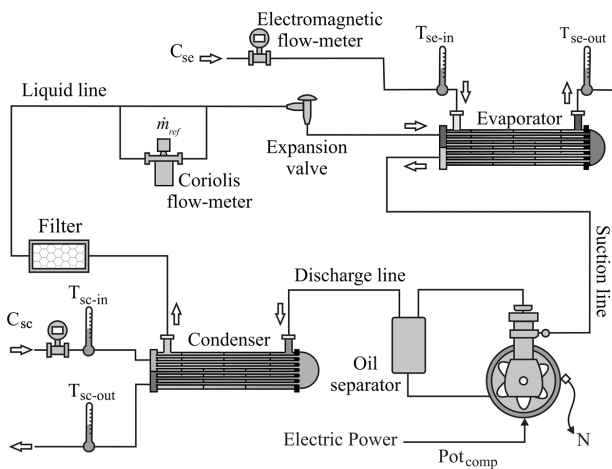

(b)

Figure 1 Experimental test bench. a) Photograph of the installation, b) Schematic diagram

The experimental facility is completed with two secondary circuits: a condensing water loop and a load simulation system, which allow changing the evaporating and condensing conditions. The load simulation system consists of a tank with electrical resistances, which permit to control the thermal load of the evaporator thanks to a variable speed pump and temperature control. The condensing system is used to fix the water conditions at the condenser using a commercial chiller with variable speed pump.

The experimental setup is fully instrumented with sensors to measure key variables such as pressures, temperatures, volumetric and mass flow rates, compressor speed and energy consumptions. The pressure transducers have an uncertainty of $\pm 0.1\%$, while the temperature sensors are calibrated with an uncertainty of $\pm 0.5\text{K}$. The volumetric fluid rates are measured with electromagnetic flowmeter with an uncertainty of $\pm 0.33\%$ and the refrigerant mass flow rate is measured using a Coriolis-effect mass flow meter with

a certified accuracy within $\pm 0.22\%$ of reading. The energy consumption is measured with digital wattmeter with a calibration specified uncertainty of $\pm 0.5\%$. The compressor rotation speed is also measured using a capacitive sensor with an uncertainty of $\pm 1\%$. The signals generated by all the sensors, as well as those provided by the measuring devices, are gathered by a National Instruments SCXI 1000 PC-based data acquisition system. Table 1 shows a range of operating main conditions in the experimental facility.

Table 1 Range of operating parameters

| Parameter | Range |
|---|-----------------------------------|
| Compressor rotation speed, N | 400-560 [rpm] |
| Evaporator volumetric flow, C_{se} | 1.0-2.7 [m^3/h] |
| Condenser volumetric flow, C_{sc} | 1.1-1.3 [m^3/h] |
| Condenser input temperature, $T_{sc,in}$ | 30-60 [$^{\circ}\text{C}$] |
| Evaporator input temperature, $T_{se,in}$ | 1.5-30 [$^{\circ}\text{C}$] |
| Superheating degree, SS | 5-10 [$^{\circ}\text{C}$] |

5. Philosophy of the model

The educational simulator is built on the characterization of the experimental facility developed [23], which is based on physical principles such as mass and energy balances, incorporating empirical correlations established through the testing, manufacturer's data and the thermal analysis of heat exchangers based on the ϵ -NTU method. The mathematical expressions established during the characterization of individual components are programmed in the EES software, which includes subroutines for estimating thermodynamic and transport properties of various refrigerants. It is noteworthy that the validation of the model was within percentage of errors of $\pm 10\%$ at all main energy parameters. Figure 2 shows the proposed structure for the model; it also indicates the input parameters such as inlet temperatures and flow rates of secondary fluids, compressor rotation speed, superheating degree, and type of refrigerant, environment temperature and percentage of concentration of the brine (water-propilenglycol). The energy performance is predicted from the input parameters. The model is also able to predict the characteristic of parameters of the main components such as heat transfer, power consumption, heat transfer area, efficiencies, among others. Terms are commonly used by mechanical engineering students in courses of the thermal area, which cause this simulator to present more useful information than other simulators for educational purposes.

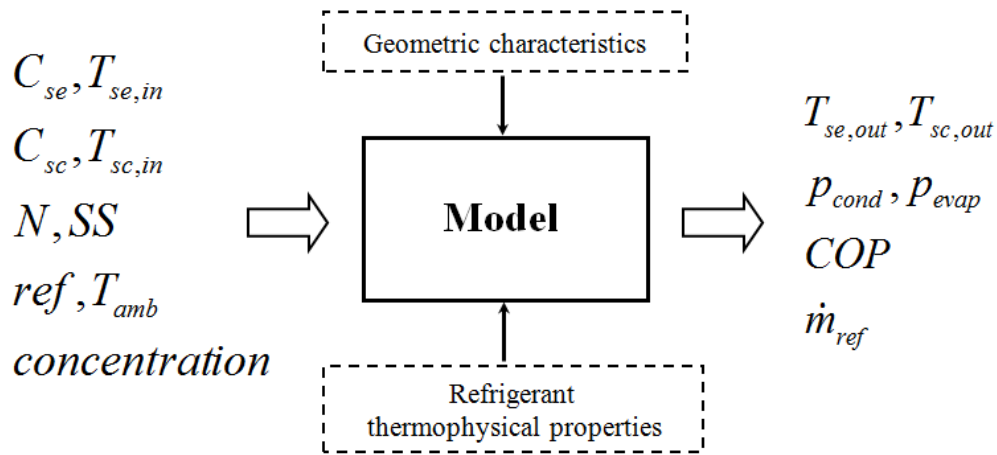

Figure 2 Structure modelling

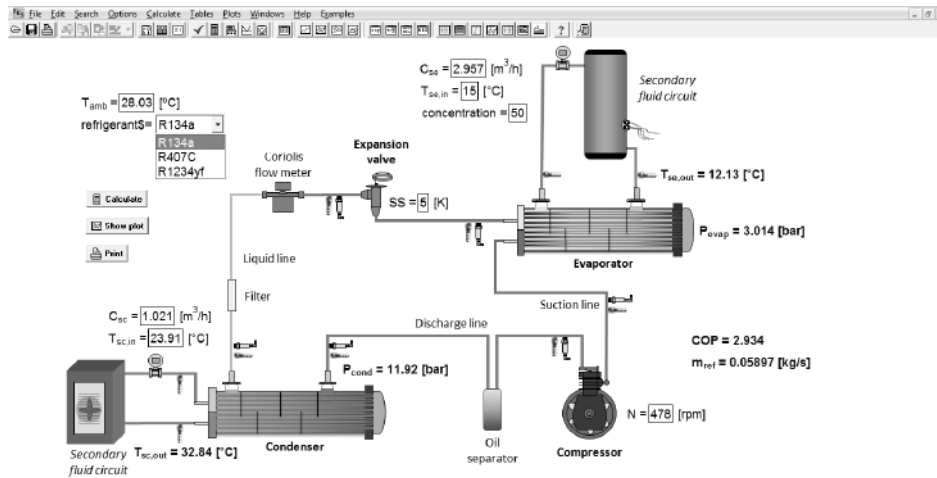

Figure 3 Main screen representing the vapor compression cycle

6. Virtual test bench: application graph

Based on the appropriate validation of the developed physical model for the experimental installation in all of its energy parameters (COP, energy consumption, working pressures, temperatures, etc.), we now proceed to develop the virtual test bench in the EES software getting a graphical simulator oriented to educational purposes. Thus, this simulator will predict performances closer to the real functioning of the installation. It is important to notice that the results or performances obtained by the simulator are based on a range of real operational conditions previously validated within the already mentioned software [23].

The professional version of software EES provides a drawing environment where the user can create a graphical representation of the system under study, drawing external applications that can be loaded in this environment. The application is oriented from an academic point of view and it is focused on teaching the vapor compression system,

as well as theoretical knowledge and experimental skills on energy management of such facilities. In general, the graphical application allows driving the behavior of the facility in a wide range of operating conditions in a graphical way, providing the students a greater understanding of such systems under different operating conditions and type of refrigerant. Thus, the screens of the application developed are described in the next section.

6.1. Simulator Features

Figure 3 shows the startup and main screen of the graphical application. It is possible to observe the basic vapor compression cycle through its four components: compressor, condenser, expansion valve and evaporator. In addition, secondary circuits with which the operating conditions of the refrigeration system are set in both heat exchangers are illustrated. In general, this screen shows the main input parameters to the installation (shown in a box). The range of magnitude of these parameters was specified in Table 1.

In this main screen, the student has the option to choose a working fluid, thus allowing the student to perform a comparison of the energy performance of the installation working with different fluids (R134a, R407C and R1234yf). Once the student or user enters the appropriate parameters, that is to say, within an operational range and makes the selection of the refrigerant, by pressing the calculate button, the simulation is obtained. In bold blue, the most representative output parameters of the system are presented such as evaporation and condensation pressure, outlet temperature of the secondary fluids, refrigerant mass flow rate, and energy performance. In addition to this screen, the students can see the main parameters in relation to the input in a graphical way by clicking "show plot" button. For instance, Figure 4 shows the behavior of the COP as a function of the condensing water temperature, $T_{sc,in}$. Students must conclude that the water temperature at the entrance of the condenser considerably affects the energy performance of the system. The best performance is obtained when the temperature of the water is relatively low, where it is possible to reach

a COP close to 3.6, when working with refrigerant R134a. When the water temperature increases, there is an increase in the temperature of condensation that results in a higher compression ratio along with a lower cooling capacity, which produces a poor energy performance.

In this way, students can analyze various behaviors by clicking on buttons located in the navigation bar, where they can observe the main variables that were introduced and the parameters involved in the system's energy analysis. Through these simulations, the student should be able to understand the behavior of certain parameters, locate optimal operating points, as well as adequately explain the influence of the proposed operating conditions. Thus, in the study of these graphs the student will be able to start the installation with the argument for energy and environmental improvements with the use of R1234yf in comparison with R134a. To return to the first screen there is the "home" button. Additionally, the students have the option to print and save the simulations with the option located at the main screen.

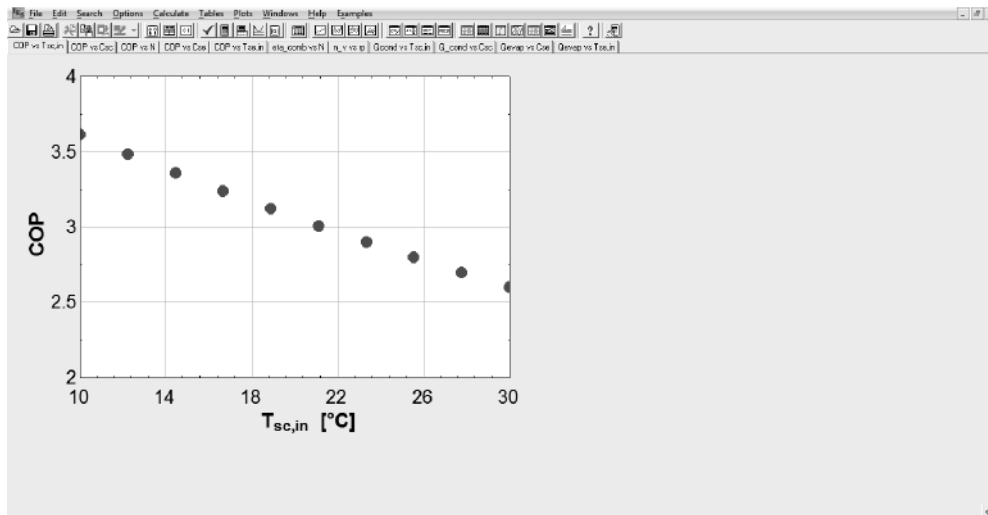

Figure 4 Influence of the condensing input temperature on energy performance

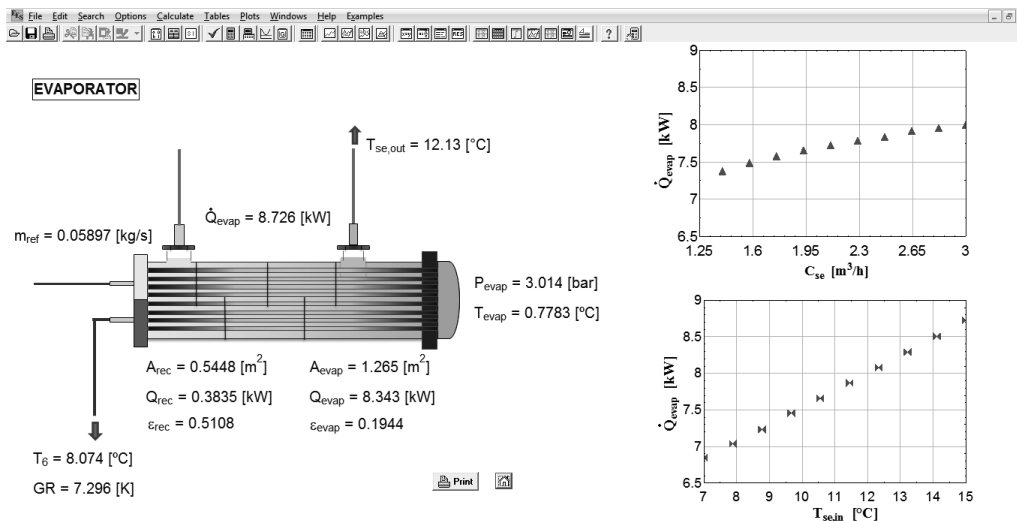

Figure 5 Energy calculations of evaporator

Moreover, from the main screen the student can analyze the characteristics' parameters of the components by simply clicking on the scheme components such as compressor, condenser and evaporator. This allows students to access other screens for visualizing and analyzing the behavior of the component through their characteristics parameters. Figure 5 illustrates the thermal behavior of the evaporator. Again, these simulations were performed using the input parameters set by the user in the main screen (see Figure 3).

Thus, in this screen the characteristic parameters of the evaporator are present, which have been modeled by dividing it in two zones associated with the state of the refrigerant: evaporation and superheating. First, on the left hand of the evaporator scheme, it is shown parameters as: evaporation pressure, P_{evap} , evaporation temperature, T_{evap} , cooling capacity, Q_{evap} , outlet temperature of the secondary fluid (brine), $T_{se,out}$, and the heat transfer area of each zone, Q_{rec} and Q_{evap} , with the respective efficiency, ε , in each zone. Second, on the right hand, the screen graphically

displays the influence of the volumetric flow rate, C_{se} , and temperature of the brine, $T_{se,in}$, on the cooling capacity of the system.

In this section, the student has the opportunity to apply the fundamentals seen in subjects as heat transfer and thermal design to check the results obtained by the simulator, and explain the reasons of the behavior. Again, the student can choose to print or return to the main screen to analyze other operating conditions or behavior of components.

The condenser and evaporator are analyzed in a similar manner. Three regions associated with the condition of the refrigerant characterize the behavior of the condenser: desuperheating zone, condensation and subcooling zone. Figure 6 shows the energy behavior for the condenser, representing the main characteristic parameters of the equipment and the influence of the input parameters of the secondary fluid on the thermal power component. The student can compare the parameters of different zones and graphical behaviors.

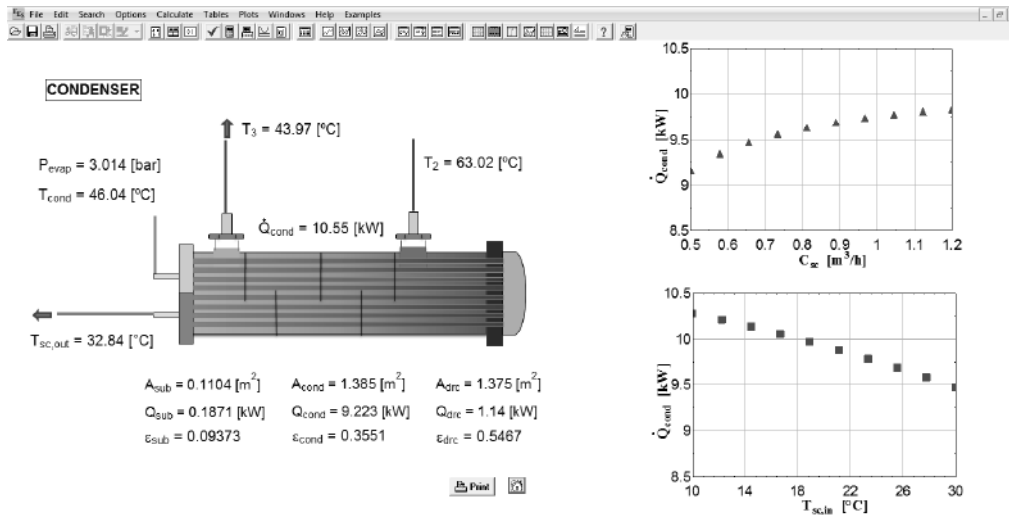

Figure 6 Energy calculations of condenser

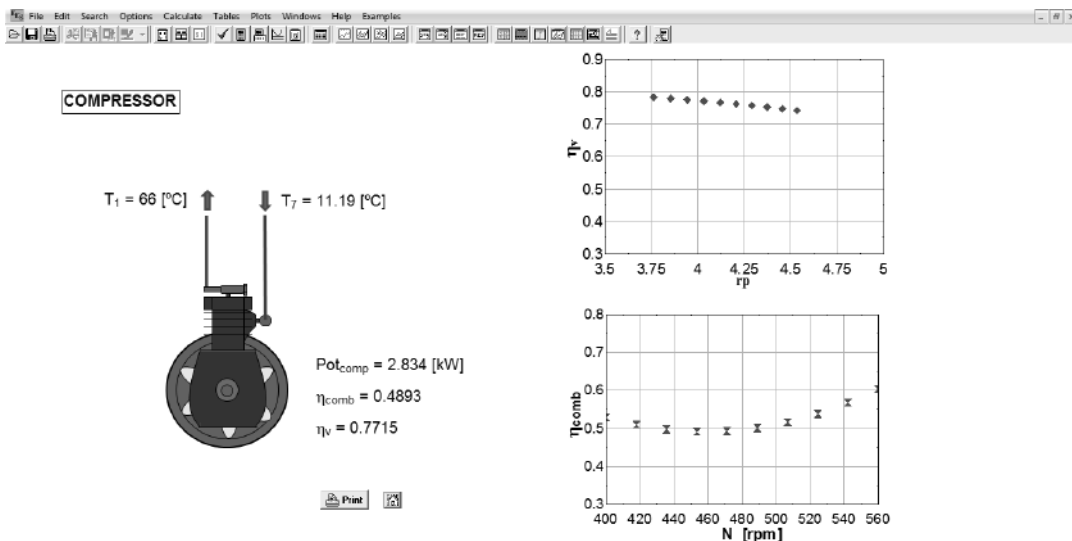

Figure 7 Behavior of compressor

Finally, Figure 7 shows the operation of the compressor. This screen illustrates the temperature of the refrigerant at the inlet (suction line), T_s , and outlet temperature (discharge line), T_d , of the compressor, as well as, the compressor energy consumption, Pot_{comp} , and its volumetric efficiency, η_v , and global efficiency, η_{comb} . The global efficiency includes the electromechanical and transmissions inefficiencies as well as the inefficiencies that occur inside the compressor as a result of friction. The graphic behavior of efficiencies is a function of variables such as compression ratio, r_p , and compressor rotation speed, N . In this way the student is able to understand each component, as well as the overall facility. Also, this screen contains buttons for printing and analysis back to the beginning. Thus, it allows the performing of the necessary simulations under different operating conditions.

7. Educative experience

The application of the virtual test bench of the refrigeration system may be a user-friendly application to engineering students. In this context, engineering educational programs seek to use software or simulators in different areas to help reinforce the student's education. Currently computer technology allows improving tools that optimize the degree of interactivity and the level of information retention in the teaching-learning process. Subjects as thermodynamics and heat transfer are areas of huge significance in the academic development of mechanical engineering students with specialization in thermal fluids. To evaluate the use of the simulator as means of virtual laboratory, 26 intermediate students (third year) were included in the subject of Refrigeration and Air Conditioning, which is given for a period of 12 weeks, with three hours of class per week. The purpose of using the virtual test consisted primarily of: i) to define the simple configuration of the experimental setup, ii) to assign a conventional refrigerant as the working fluid (R134a), iii) to study and load of the file under certain operating conditions, iv) when the thermodynamic steady state was evaluated, the student must reproduce the information obtained in respect to the energy performance of the facility, COP. The students should also reproduce the main parameters of the heat exchangers as thermal power and efficiency. Finally, the student must repeat the above steps, but now, by assigning an alternate refrigerant as R1234yf or R407C, in order to compare the energy performances between the refrigerants while corroborating what was found in the literature regarding the tendency of alternative refrigerants. It is important to mention that initially the virtual bench was loaded to work with R134a, whenever students require changing the refrigerant. They should also research and explore adequate conditions for the use of the simulator with other refrigerants.

Thus, 73% of students who used the virtual test bench achieved the same results by using expressing thermodynamic and heat transfer equations for each element of the installation. The student group concluded that the virtual test bench is easy, but under a prior

knowledge of the theory of vapor compression systems; in addition, the simulator displays particular parameters of heat exchange equipment and comprehensive information about the performance of the compressor, all these aspects strengthen the student's formation.

On the other hand, in order to evaluate the academic performance of the students that utilized the virtual bench, it can be broadly mentioned that an increase in the use of theoretical concepts was noticed in the students group. Due to the explanation the students were asked to develop on the different energy performances of the installation, they also have to reason the influence of the input parameters [operational conditions] to the system. Moreover, it was decided to organize groups of 10 students each, randomly assigned; the first group took the course of Air Conditioning and refrigeration in which they used the virtual bench as practice guide, while the other group did not use the use the tool. With this evaluation in a simple way, it is concluded that the students who learned and used the simulator obtained a higher average achievement of about 16%, in respect to the group of students who did not use the virtual bench.

Finally, the use of the virtual bench can encourage students to make their own decisions when facing a real situation and begin to develop skills that a plant engineer should process. The simulator for education becomes a useful tool to achieve more active classes, task scheduling analysis, technical discussions and integration of knowledge in the laboratory. The simulator is available to students via web site (<http://www.ingenierias.ugto.mx/profesores/belman/documentos/>).

8. Conclusions

In this paper an educational virtual test bench for a vapor compression system developed in EES software was presented. The simulator allows the prediction of the refrigeration system performance using input variables. Specifically, the input variables of the simulator are: the compressor rotation speed, the volumetric flow rates, and the temperature of the secondary fluids (at the evaporator inlet and at the condenser inlet). The main conclusions about this paper can be summarized as follows:

- The simulator is very robust because it can be used with a wide range of operating conditions.
- The resulting application is simple and user friendly for a wide range of people, namely engineering students.
- The student can see many situations, explore what happens in different conditions and, in general, see things developed on the screen as a result of the inputs.
- The simulator is oriented, in addition to teaching, to management and understanding refrigeration systems. The use of the simulator is a simple way

enabling students to interact in a main screen that represents the vapor compression system refrigeration.

- This application results in a useful tool in the area of refrigeration research because it responds to the need for quick data analysis and evaluation of the performance of the system. This tool can be used in engineering education in order to strengthen the knowledge about the study of refrigeration in vapor compression system, additionally to subjects as thermodynamics, heat transfer and thermal design.

9. Acknowledgements

The authors are grateful to ISTENER Research Group of University of Jaume I for the sponsorship for this work.

10. References

1. E. Smirnov and V. Bogun, "Information and communication technology in science learning as a tool for 'scientific thinking' in engineering education", *Natural Science*, vol. 2, no. 12, pp. 1400-1406, 2010.
2. P. Axaopoulos and G. Pitsilis, "Energy software programs for educational use", *Renewable energy*, vol. 32, no. 6, pp. 1045-1058, 2007.
3. J. Jiménez, J. Ramírez and J. González, "Collaborative robotics modular system used in education", *Rev. Fac. Ing. Univ. Antioquia*, no. 58, pp. 163-172, 2011.
4. D. Mendes, C. Marangoni, A. Meneguelo, R. Machado and A. Bolzan, "Educational simulator for multicomponent distillation research and teaching in chemical engineering", *Comput. Appl. Eng. Educ.*, vol. 18, no. 1, pp. 175-182, 2010.
5. A. Rivas, T. Gómez and J. Ramos, "The application of spreadsheets to the analysis and optimization of systems and processes in teaching of hydraulic and thermal engineering", *Comput. Appl. Eng. Educ.*, vol. 14, pp. 256-268, 2006.
6. A. Lopes, "A versatile software tool for the numerical simulation of fluid flow and heat transfer in simple geometries", *Comput. Appl. Eng. Educ.*, vol. 18, no. 1, pp. 14-27, 2010.
7. K. Forbus *et al.*, "CyclePad: An articulate virtual laboratory for engineering thermodynamics", *Artificial Intelligence*, vol. 114, no. 1-2, pp. 297-347, 1999.
8. F. Machuca and O. Urresta, "Educational software for the teaching of the dynamics and control of shell and tube heat exchangers", *Rev. Fac. Ing. Univ. Antioquia*, no. 44, pp. 52-60, 2008.
9. A. Martín and Mato, "Hint: An educational software for heat exchanger network design with the pinch method", *Education for chemical engineers*, vol. 3, no. 1, pp. 6-14, 2008.
10. S. Dormido, "Control learning: Present and future", *Annual Rev. Control*, vol. 28, no. 1, pp. 115-136, 2004.
11. M. Dubey, S. Rajput, P. Nag and R. Misra, "Energy analysis of a coupled power-refrigeration cycle", *Proceedings of IMechE, Part A: Power and Energy*, vol. 224, pp. 749-759, 2010.
12. L. Pérez, J. Ortiz and C. Pout, "A review on buildings energy consumption information", *Energy and Buildings*, vol. 40, pp. 394-398, 2008.
13. S. Ledesma and J. Belman, "Application of artificial neural networks for generation of energetic maps of a variable speed compression system working with R1234yf", *Applied Thermal Engineering*, vol. 69, no. 1-2, pp. 105-112, 2014.
14. B. Bolaji, S. Adejuyigbe and J. Olonila, "Performance simulation of vapour compression refrigeration systems using ozone-friendly hydro-fluorocarbon refrigerants", *Annals of Faculty Engineering Hunedoara - International Journal of Engineering*, vol. 12, no. 3, pp. 177-182, 2014.
15. L. Genik, R. Davis and C. Somerton, "Vapor-compression refrigeration simulation and tutorial", in *American Society for Engineering Education (ASEE) Annual Conference*, Montreal, Canada, 2000, pp. 6761-6770.
16. J. Sieres and J. Fernández, "Simulation of compression refrigeration systems", *Comput. Appl. Eng. Educ.*, vol. 14, pp. 188-197, 2006.
17. IPU, *CoolPack*. [Online]. Available: <http://en.ipu.dk/Indhold/refrigeration-and-energy-technology/coolpack.aspx>. Accessed on: Aug. 15, 2014.
18. J. Corberán, J. Gonzalez, P. Montes and R. Blasco, "'ART' a computer code to assist the design of refrigeration and A/C equipment", in *9th International Refrigeration and Air Conditioning Conference*, West Lafayette, USA, 2002, pp. 347-354.
19. J. Brown, P. Domanski and E. Lemmon. "Cycle_D version 4.0: Theoretical vapor compression cycle design program", in *3rd IIR Conference on Thermophysical Properties and Transfer Processes of Refrigerants*, Boulder, USA, 2009, pp. 170-177.
20. R. Antón, H. Jonsson, J. Ramos, T. Gómez and A. Rivas, "Refrigerating cycle simulator: system modelling, educational implementation and assessment", *International Journal of Engineering Education*, vol. 25, pp. 324-332, 2009.
21. I. Eames, T. Brown, J. Evans and G. Maidment, "Description and validation of a computer based refrigeration system simulator", *Computers and Electronics in Agriculture*, vol. 85, pp. 53-63, 2012.
22. J. Mendoza, J. Belman, A. Gallegos, A. Mota and J. Navarro, "Computational tool for experimental refrigeration system analysis using spreadsheets", *Dyna*, vol. 89, pp. 608-615, 2014.
23. J. Belman, J. Navarro, D. Ginestar and V. Milian, "Steady-state of a variable speed vapor compression system using R134a as working fluid", *International Journal of Energy Research*, vol. 34, pp. 933-945, 2010.